

ISO - View

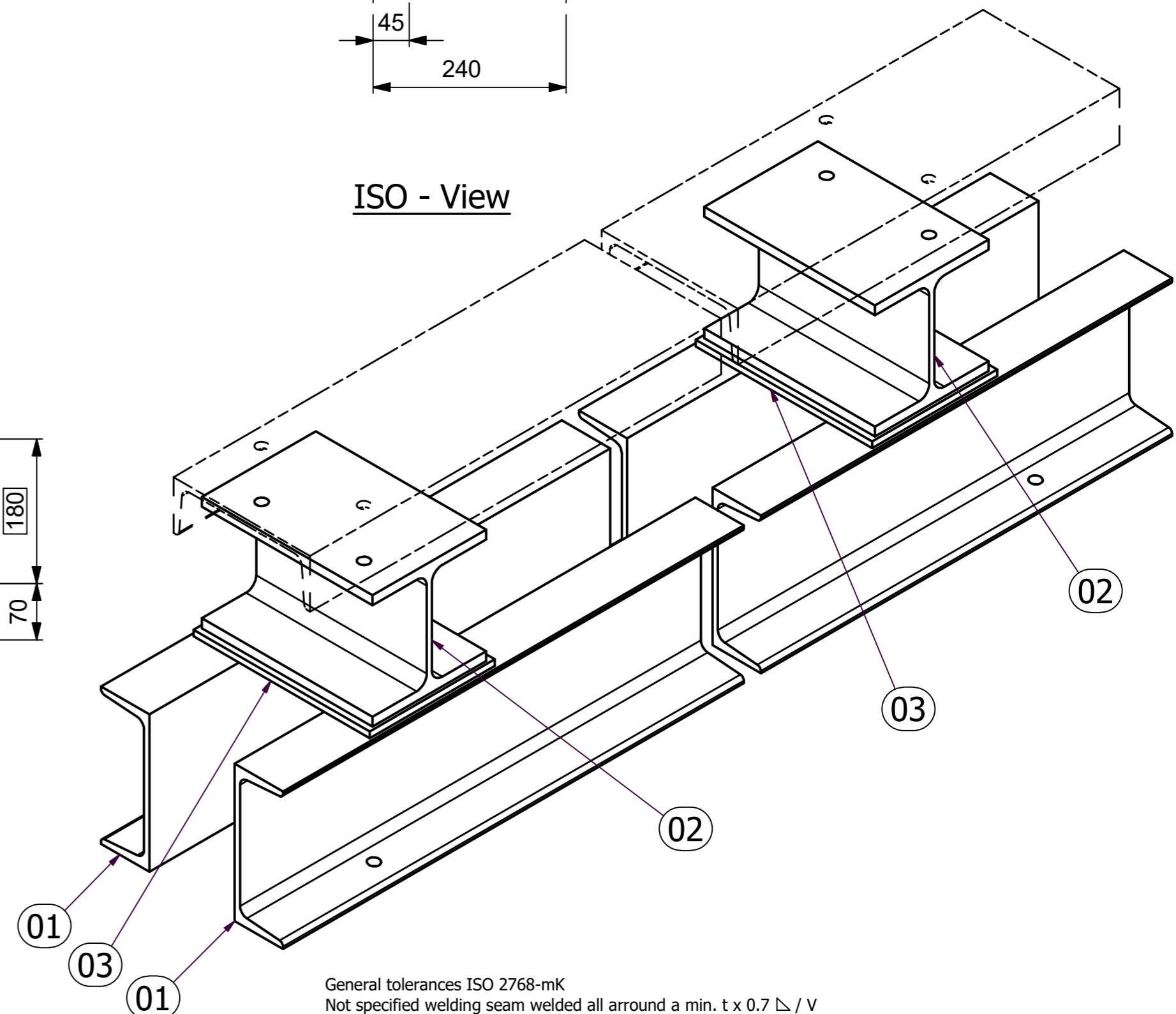
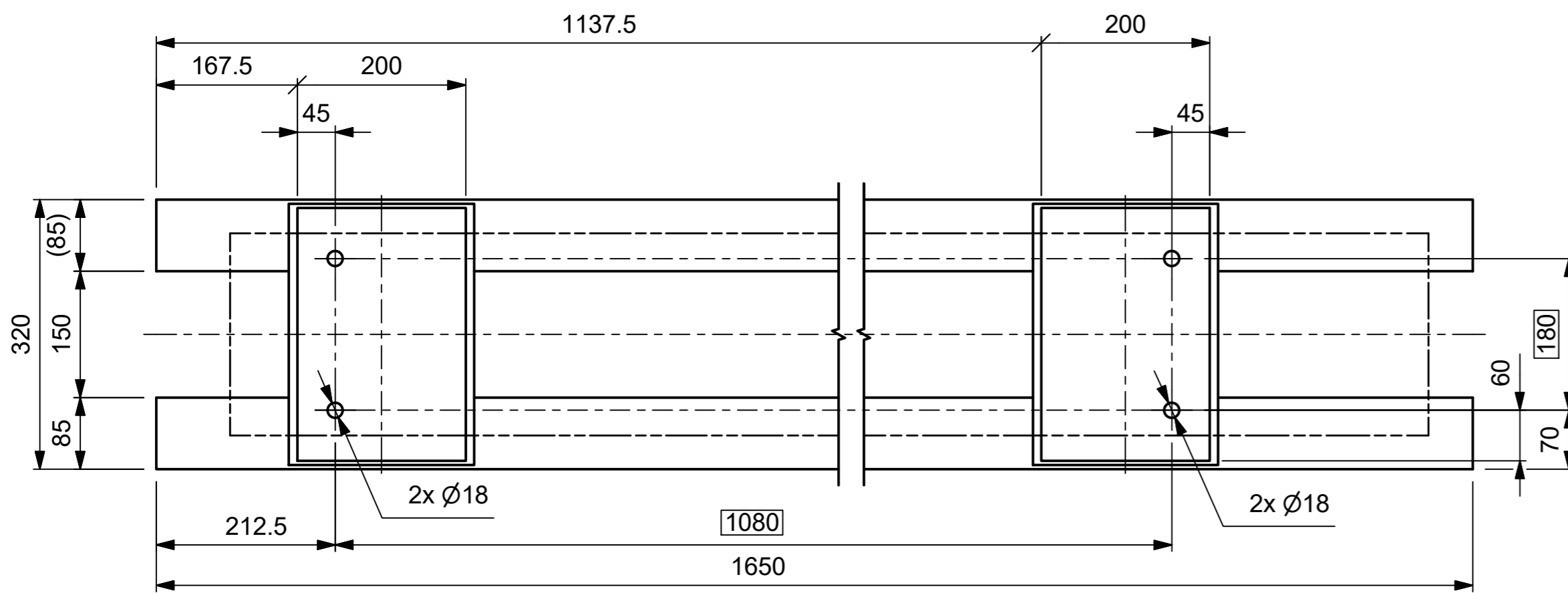

General tolerances ISO 2768-mK
Not specified welding seam welded all around a min. $t \times 0.7 \Delta / V$

C				ohne Stückliste/without PL	<input type="checkbox"/>
B	Profile size changed, dimension changed, sheets added	05.04.2019	JP	mit Stückliste, gleicher Zeichnung-Nr.	<input type="checkbox"/>
A	Holes added, dimensions added	17.01.2019	ZZ	with PL same drwg.-no.	<input checked="" type="checkbox"/>
Änderung index	Art der Änderung kind of correction	Datum date	Visum visa	mit Stückliste, anderer Zeichnung-Nr. with PL another drwg.-no.	<input type="checkbox"/>

SCHUBAG
Support for Progressive cavity pump

Masse / Mass
156,9 kg

Auftrag Nr.
order number
K-19 0009

Massstab
scale
1 : 5

drawn Y. Ranjan 30.11.2018
checked C. La Vista 30.11.2018
approved C. Candussi 30.11.2018

Pump support 10

Autodesk Inventor- Release 2017

46 933 B

schubag
Pumpen | Service | Effiziente Lösungen

Item	Part No.	Description	Typ	Length	Norm / Dimension	Pieces	Material	Drawing No.	Supplier
01	10-900-12-010	U - Profile	UNP 240	1650,0 mm	DIN 1026-1	2	S235JR		Base frame supplier
02	10-900-08-006	HEB - Profile	HEB 200	300,0 mm	DIN 1025-2	2	S235JR		Base frame supplier
03	10-900-03-005	Plate	BLE 10	310,0 mm	EN 10025	2	S235JR	L310 x W220 mm	Base frame supplier

